

Background

The flow of charges through a circuit is best illustrated by actually constructing such circuits, and analyzing them using concepts covered in class.

Objectives

To construct and analyze the behavior of four circuits: a simple switch circuit, a simple rheostat (variable resistance) circuit, a series circuit, and a parallel circuit.

Equipment

Leads, alligator clips, two 6.3-V light bulbs and sockets, an electric motor, two SPDT switches, 9-V battery and cap, multimeter.

Procedure

Part A. Simple Circuit

1. Construct *both* of the following simple circuits

- Light with switch
- Motor with switch and speed control, or light with switch and dimmer

For both of these circuits, you'll need to:

- a. Build the circuit and demonstrate (to someone, anyone!) that it works.
- b. Draw a schematic diagram of the circuit using the appropriate symbols¹.
- c. Use a multimeter² to determine:
 - i. the current flowing through each device in the circuit, and
 - ii. the potential difference (voltage) over the battery and the light/motor
- d. Identify on your schematic diagram
 - i. the current flowing through each device in the circuit, and
 - ii. the potential before and after each device in the circuit.

Part B. Series and Parallel Circuits

1. Construct *both* of the following simple circuits

- Two lights in series (no switch necessary), connected to a battery.
- Two lights in parallel (no switch necessary), connected to a battery.

For both of these circuits, you'll need to:

- a. Build the circuit and demonstrate (to someone, anyone!) that it works.
- b. Draw a schematic diagram of the circuit using the appropriate symbols.
- c. Use a multimeter to determine:
 - i. the current flowing through each device in the circuit, and
 - ii. the potential difference (voltage) over the battery and the light/motor
- d. Identify on your schematic diagram
 - i. the current flowing through each device in the circuit, and
 - ii. the potential before and after each device in the circuit.
- e. Identify what happens in each circuit when you unscrew one of the light bulbs.

Questions

Part A. Simple Circuit

1. What was the relationship between the potential difference measured over the battery and the potential difference over the light or motor? Which of these devices produced an increase in potential in the circuit, and which of these devices caused a decrease in the potential in the circuit?



² See the end of this lab for *vital* information on how to correctly operate a multimeter!

Lab: Simple Circuits

AP Physics

Part B. Series and Parallel Circuits

1. What was the relationship between the potential difference measured over the battery, and the potential differences over the two lights in each circuit?
2. What happened when you unscrewed one of the light bulbs in each circuit? What did the behavior of the light bulbs reveal about the flow of current through the circuit?

Notes on Using a Multimeter

Part A. Measuring Change in Potential / Voltage

To measure a change in potential over / across a device (resistor, battery, light bulb, motor, capacitor, etc.):

1. Place the red (positive) lead in the + jack.
2. Place the black (negative, common, ground) lead in the - jack.
3. Turn the multimeter on (if it has a power switch).
4. Set the multimeter initially to its appropriate Voltage setting. If you're not sure what the potential is that you might be measuring, use a higher setting, and adjust it downwards as necessary once the circuit is operating.
5. Place the red lead from the Voltmeter at the high potential end of the device, and the black lead from the Voltmeter on the other side of the device, at the low potential end. (See diagram.)
6. Read the potential difference across the device on the meter.

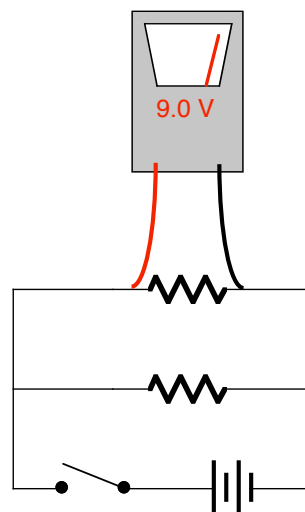

Part B. Measuring Current through a circuit

NOTE: It is extremely easy to destroy a meter when trying to measure current! Follow these instructions carefully, and have the instructor check your setup before you apply power!

To measure current flow *through* a circuit:

1. Place the red (positive) lead in the + jack.
2. Place the black (negative, common, ground) lead in the - jack.
3. Turn the multimeter on (if it has a power switch).
4. Set the multimeter initially to its appropriate Current setting. If you're not sure what the current is that you might be measuring, use the highest setting, and adjust it downwards as necessary once the circuit is operating.
5. **Disconnect the circuit where you want to measure current.** Then place the red lead from the Ammeter at the high potential wire, and the black lead from the Ammeter at the low potential wire. The ammeter acts to complete the circuit. (See diagram.)
6. Read the current through this part of the circuit on the meter.

